

**BATTERY SWITCHES  
INSTALLATION AND OPERATING INSTRUCTIONS**

For use with alternators and generators rated 6-32 V.D.C.  
Switch rating: 315 amperes continuous, 450 amperes intermittent.

All wiring to the switch shall be performed by a QUALIFIED MARINE ELECTRICIAN, and in accordance with the "Fire Protection Standard For Motor Craft", N.F.P.A.\* No. 302, The Standards of the American Boat and Yacht Council, Inc.\*, and the U.S.C.G.\* Safety Standards for Boat Electrical Systems (33 CFR 183).

- CAUTION:**
- (1) Make sure connections at terminals No. 1 and No. 2 are of the same polarity.
  - (2) Always STOP engines before switching to "OFF" position. Make-Before-Break feature allows switching between 1-all-2 positions with running engines. Erratic operation, particularly after very long periods of idleness, can be cleared by rapidly switching back and forth briskly several times without any load connected.

- NOTE:**
- (1) Locate switch to keep battery cables as short as possible.
  - (2) If switch is to be mounted in an area subject to corrosion, it is recommended that a liquid electrical coating be applied to the terminal connections.
  - (3) Mounting screw size #10 pan head or round head. Mount on a flat surface and do not over-tighten screws to prevent deforming the switch body.
  - (4) Protective skirt panels can be removed as required for cable positioning when installing the switch.
  - (5) Terminal stud size is 3/8 inch. Torque terminal nuts to 15 ft-lbs.

**OPTIONAL ACCESSORY**

Key Lock - Switch can be locked only in the "OFF" position. Key can be removed in either the locked or unlocked position.

The following diagrams illustrate typical installations.

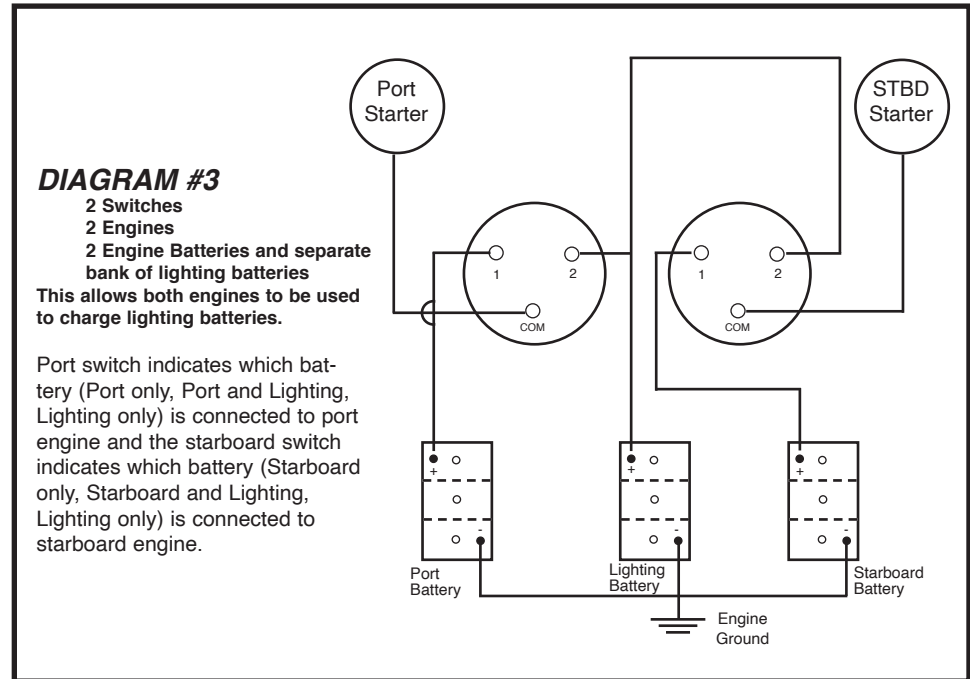
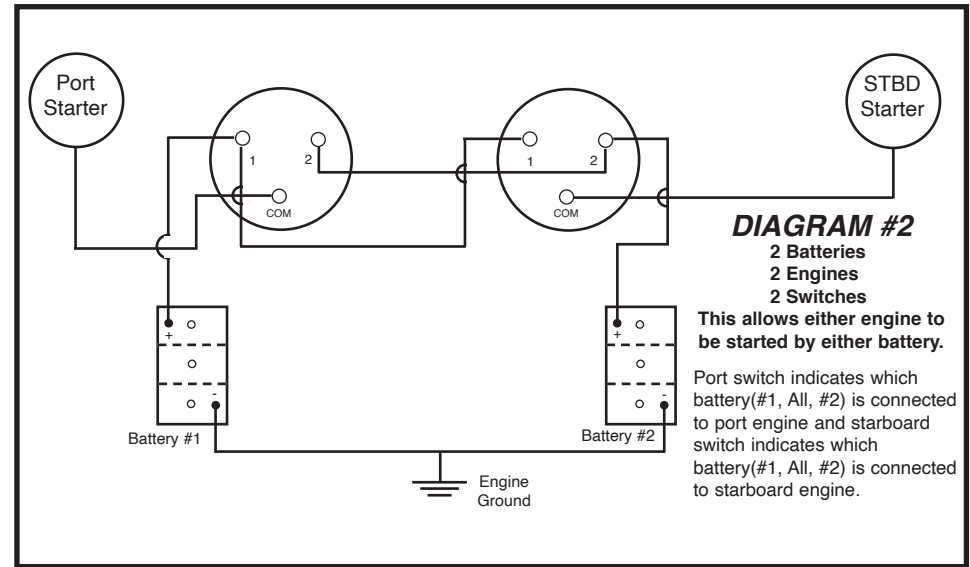
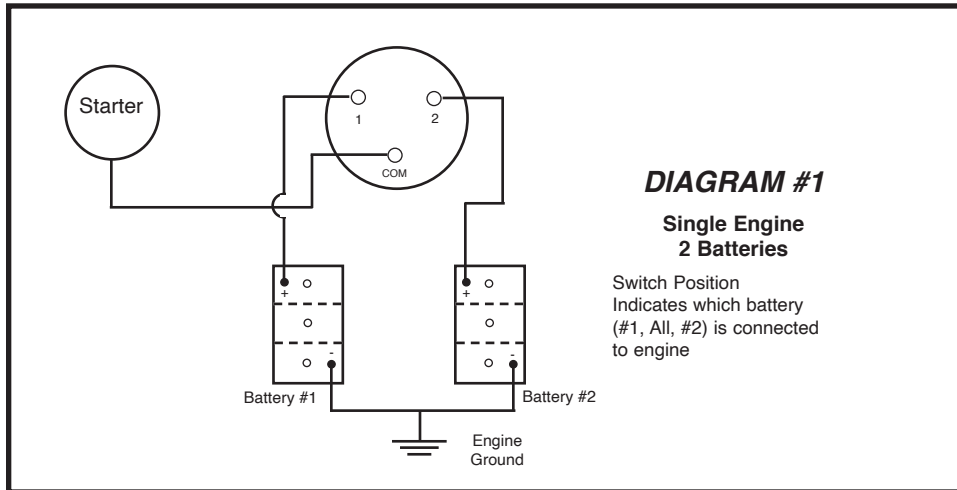

\* Above referenced standards can be obtained from:

1. American Boat & Yacht Council, Inc.  
613 Third Street, Suite 10  
Annapolis, MD 21403
2. U.S. Coast Guard  
Washington, D.C. 20593  
(or your local C.G. office)
3. N.F.P.A.  
1 Batterymarch Park  
Quincy, MA 02169